



SARMAAFARIN

**39HX Series
Air Handling Unit**

Double Skin, Two Inches Insulation

AEROACOUSTIC



Certificate No.: 9190.C308
FORM SSI - 39HX (1403)

39HX

850 up to 52600 cfm

The forehead text represents an air handling with outstanding characteristics to assure new HVAC policies and fulfill our customer's satisfaction. 39HX brings forward more details to comply with your needs so let us dive into the contents:

Introduction

Chapter One: Technical Data Page

1.1 Product variants and modules	2
1.2 Physical Data	4
1.3 Air Handling Selection	7

Chapter Two: Technical design Details and standards

2.1 Casing	9
2.2 Filters	10
2.3 Coils	16
2.4 Humidifier	20
2.5 Fans	20

Chapter Three: Appendix

3.1 Applications
3.1 Standards

Chapter Four: Tests and Control

4.1 Remote Monitoring System	24
4.2 AHU Selection Software	25
4.3 Tests	27

Sarma Afarin 39HX Series of Air Handling Units incorporate state-of-the-art technology to provide heating and cooling and meet filtration, pressurization, condensation, control, and sanitization standards required by the critical applications where clean and ultra-clean air is needed. It fits applications that are sensitive to dust and other contaminants, such as residences and residential buildings, food industry,

wood industry, textile industry, printing and paper industry, metalworking and automotive industries. It could also meet the criteria of applications where extended hygiene requirements are needed and the entry of particles and germs need to be minimized, such as hospitals, surgery rooms and pharmaceutical industry.

The units are custom engineered to produce the specified psychrometric conditions and to achieve the environmental design criteria for the area being served. This is the result of detailed research in the thermal, aerodynamic and acoustic fields, and allows Sarma Afarin to offer technically superior units at competitive prices.

Taking the requirements of our customers into consideration, our design engineers can design different configurations of air handling units to suit different types of applications.

39HX series specifications

Using plug fans which eliminates belt abrasion and makes cleaning easier.

Using steam humidifiers in order to meet hygiene criteria.

Using curved shape and continuous-single profile casing which makes cleaning easier, reduces the accumulation of particles, and reduces leakage.

Using stainless steel for surfaces that are potentially in contact with condensed water and humidifier (Units with all internal surfaces made of stainless steel are available upon request).

Using multiple stages of filtration which ensures the minimum presence of particles and contaminants in supply air.

For Extended Hygiene Requirements, a stage of HEPA filters is included in the unit.

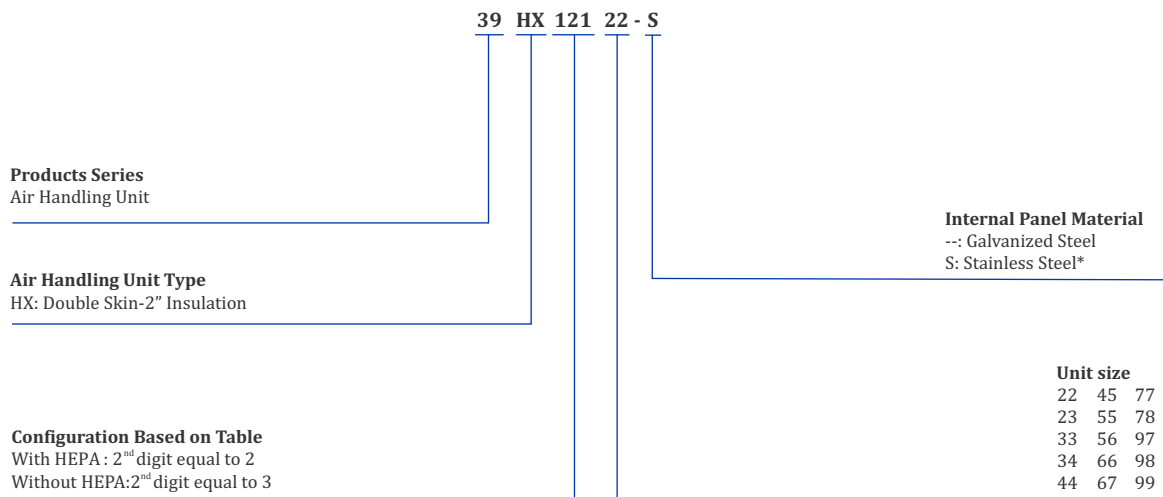

*In hygiene applications Internal Panel material should be made of stainless steel(EUROVENT-RS/10).

The 39HX line of Sarma Afarin air handling units is based on a modular system. The first and second digits of unit size denote the number of modules in height and width respectively. This modular sizing determines the cross-section available for air flow and encodes the unit size. Each module has a constant value of 315 mm, which determines exterior dimensions of units using the following formulas:

$$\text{Dimension} = (n \times 315) + 40 \text{ mm}$$

The following picture clarifies modular dimensions for 39HX12145 model as an example:

$$\text{Height} = (4 \times 315) + 40 = 1300 \text{ mm}$$

$$\text{Width} = (5 \times 315) + 40 = 1615 \text{ mm}$$

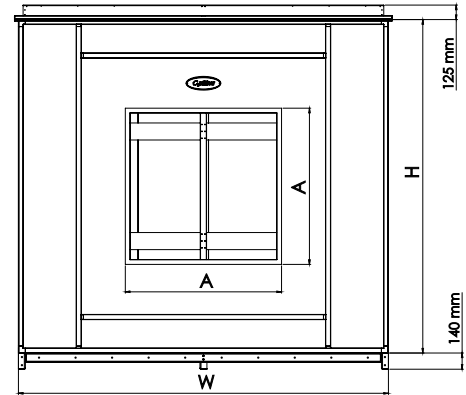
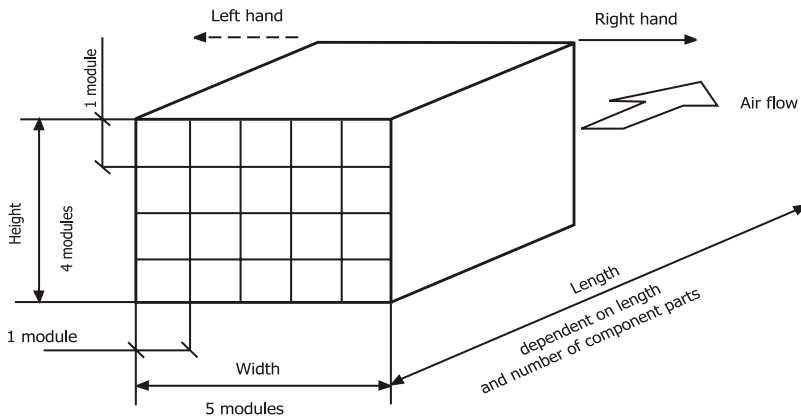

Unit Size			22	23	33	34	44	45	55	56
Air Volume Flow Rate[CFM]	FPM	400	840	1560	2320	3320	4440	5760	7240	9040
		450	945	1755	2610	3735	4995	6480	8145	10170
		500	1050	1950	2900	4150	5550	7200	9050	11300
		550	1155	2145	3190	4565	6105	7920	9955	12430
		600	1260	2340	3480	4980	6660	8640	10860	13560
		700	1470	2730	4060	5810	7770	10080	12670	15820
Coil Face Area		[sq. ft.]	2.1	3.9	5.8	8.3	11.1	14.4	18.1	22.6
Cross Section Dimention		W[mm]	670	985	985	1300	1300	1615	1615	1930
		H[mm]	935	935	1250	1250	1565	1565	1880	1880
		W[No Module]	2	3	3	4	4	5	5	6
		H[No Module]	2	2	3	3	4	4	5	5
Air Discharge		A[mm]	230	290	450	450	590	645	905	905
		V[mm]	220	190	268	268	355	328	355	355
		O[mm]	220	348	268	425	355	485	355	513

Unit Size			66	67	77	78	97	98	99
Air Volume Flow Rate[CFM]	FPM	400	11720	13920	16040	18760	23760	26920	30080
		450	13185	15660	18045	21105	26730	30285	33840
		500	14650	17400	20050	23450	29700	33650	37600
		550	16115	19140	22055	25795	32670	37015	41360
		600	17580	20880	24060	28140	35640	40380	45120
		700	20510	24360	28070	32830	41580	47110	52640
Coil Face Area		[sq. ft.]	29.3	34.8	40.1	46.9	59.4	67.3	75.2
Cross Section Dimention		W[mm]	1930	2245	2245	2560	3190	3190	3190
		H[mm]	2195	2195	2510	2510	2510	2825	3140
		W[No Module]	6	7	7	8	10	10	10
		H[No Module]	6	6	7	7	7	8	9
Air Discharge		A[mm]	905	905	1000	1220	1220	1220	1220
		V[mm]	513	513	623	513	513	670	828
		O[mm]	513	670	623	670	985	985	985

Sarma Afarin 39HX Air Handling Units can be manufactured in multiple configurations, with a wide selection of components to meet customer requirements. To ensure the maximum flexibility and the best solution for customer's application, units are available in 315 mm increment in both height and width.

We have considered 36 configurations with different arrangement of filters and other components, which could cover a wide variety of our customers' demands. Upon the request, other configurations are available to meet the customer requirements.

Sections Arrangement (by default all configurations have MB, LVF, PLN, and Fan sections*)

HUM*	●	●	●				●	●	●				●	●	●			
BF*	●	●		●	●		●	●		●	●		●	●		●	●	
BC*	●		●	●		●	●		●	●		●		●	●	●		●
BFS*	●	●	●	●	●	●							●	●	●	●	●	●
PLT*	●	●	●	●	●	●												
Configuration NO.	121	122	123	124	125	126	221	222	223	224	225	226	321	322	323	324	325	326
No. Modules HEPA Included	19	18	17	17	16	15	17	16	15	15	14	13	18	17	16	16	15	14
Length[mm]	6238	5923	5608	5608	5293	4978	5608	5293	4978	4978	4663	4348	5923	5608	5293	5293	4978	4663
Configuration NO.	131	132	133	134	135	136	231	232	233	234	235	236	331	332	333	334	335	336
No. Modules HEPA Excluded	17	16	15	15	14	13	15	14	13	13	12	11	16	15	14	14	13	12
Length[mm]	5608	5293	4978	4978	4663	4348	4978	4663	4348	4348	4033	3718	5293	4978	4663	4663	4348	4033

*PLT: Pleated Filter(315 mm), BFS: Bag Filter(630 mm), BC: Heating Coil(315 mm), BF: Cooling Coil(630 mm), HUM: Humidifier(630 mm)
 *MB: Mixing Box(630 mm), FAN(1260 mm), PLN: Plenum(315 mm), LVF: Aluminum Low Velocity Filter(630 mm)

The Unit length is determined by the number and size of internal components required. The side for services (connections and access) is defined as right hand or left hand in the direction of the air flow. Thanks to the modular construction of the 39HX series, it can meet the limitations of customer's spacing and the

requirements of a wide range of applications with different air flow rates. In the following chart, the flow rate of units at different flow speeds are shown, and customers can easily use this chart to choose an appropriate unit that meets their required flow rate.

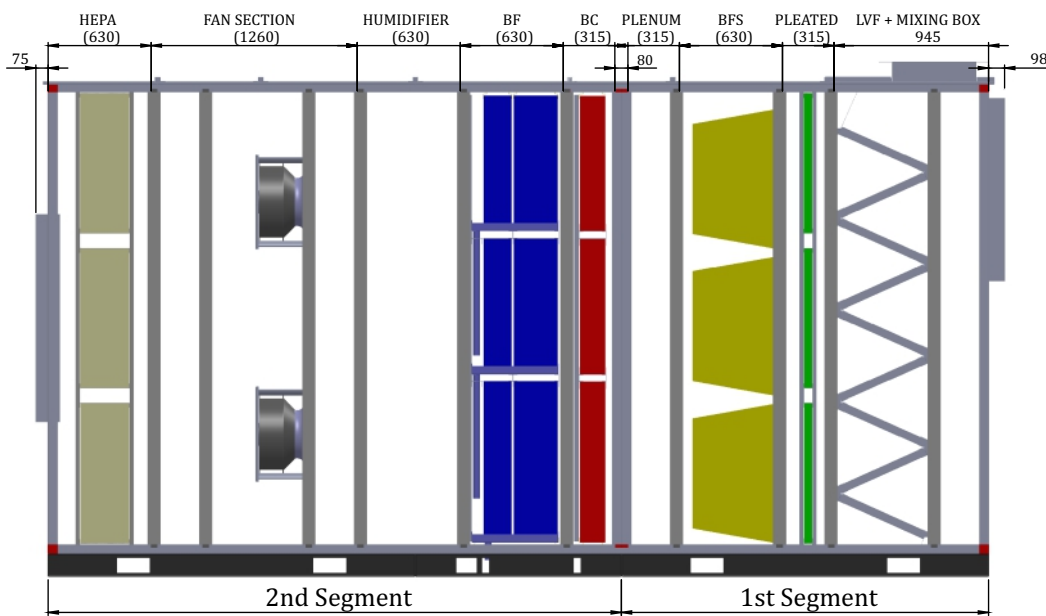

Note: Dimensions are in mm.

Table 3 Total Weight(kg) of different Configuration With HEPA*

AHU Size	121	122	123	124	125	126	221	222	223	224	225	226	321	322	323	324	325	326
22	853	812	765	729	687	641	721	679	633	597	555	508	817	775	728	692	651	604
23	1052	1002	939	915	865	801	891	841	778	754	704	640	1008	959	895	871	821	757
33	1219	1159	1072	1072	1011	924	1037	976	889	889	829	741	1167	1107	1020	1020	959	872
34	1439	1367	1267	1277	1206	1105	1225	1154	1053	1064	993	892	1378	1307	1206	1217	1146	1045
44	1623	1541	1422	1451	1369	1250	1388	1306	1187	1216	1134	1015	1554	1472	1353	1382	1300	1181
45	1860	1767	1627	1675	1582	1441	1595	1502	1362	1410	1317	1177	1782	1689	1548	1596	1504	1363
55	2198	2067	1880	1971	1841	1654	1907	1776	1589	1680	1550	1363	2112	1981	1794	1885	1754	1567
56	2485	2337	2141	2245	2097	1901	2164	2016	1821	1924	1776	1580	2389	2241	2045	2149	2001	1805
66	2753	2580	2361	2502	2329	2110	2408	2235	2017	2157	1985	1766	2647	2474	2256	2396	2223	2005
67	3053	2869	2632	2788	2604	2368	2675	2491	2254	2410	2227	1990	2936	2752	2516	2672	2488	2251
77	3311	3104	2847	3036	2829	2572	2905	2698	2440	2630	2423	2165	3186	2978	2721	2910	2703	2446
78	3578	3353	3083	3289	3065	2795	3141	2917	2647	2853	2629	2359	3441	3217	2946	3153	2928	2658
97	4151	3903	3613	3836	3588	3298	3652	3404	3114	3337	3089	2799	3993	3745	3455	3678	3430	3140
98	4453	4190	3888	4128	3865	3563	3923	3659	3358	3598	3334	3033	4283	4020	3718	3958	3695	3393
99	4760	4481	4168	4424	4145	3832	4195	3916	3603	3859	3580	3267	4580	4301	3987	4244	3965	3651

* Weight of 2 rows and 6 rows are considered for heating and cooling coils, respectively

Table 4 - Total Weight(kg) of different Configuration Without HEPA*

AHU Size	131	132	133	134	135	136	231	232	233	234	235	236	331	332	333	334	335	336
22	775	733	686	650	609	562	665	623	577	541	499	452	738	696	650	614	572	525
23	949	899	836	812	762	698	814	764	700	676	626	563	905	855	792	768	718	654
33	1093	1032	945	945	885	797	936	875	788	788	728	640	1041	981	893	893	833	745
34	1283	1211	1110	1121	1050	949	1098	1026	925	936	865	764	1222	1151	1050	1061	989	889
44	1438	1356	1237	1266	1184	1065	1231	1149	1031	1059	977	859	1369	1287	1168	1197	1115	996
45	1641	1548	1408	1456	1363	1223	1408	1315	1174	1222	1130	989	1563	1470	1329	1377	1285	1144
55	1947	1816	1629	1721	1590	1403	1687	1557	1370	1461	1330	1143	1861	1730	1543	1634	1504	1317
56	2195	2047	1851	1954	1807	1611	1908	1761	1565	1668	1520	1325	2099	1951	1755	1858	1711	1515
66	2425	2253	2034	2175	2002	1783	2115	1943	1724	1864	1692	1473	2320	2147	1929	2069	1896	1678
67	2682	2499	2262	2418	2234	1997	2342	2158	1922	2078	1894	1657	2566	2382	2145	2301	2118	1881
77	2898	2691	2434	2623	2416	2158	2529	2322	2065	2254	2047	1789	2772	2565	2308	2497	2290	2032
78	3117	2893	2622	2829	2605	2334	2721	2497	2227	2433	2209	1938	2981	2756	2486	2692	2468	2198
97	3596	3348	3058	3281	3033	2743	3143	2895	2605	2828	2580	2290	3438	3189	2899	3123	2874	2585
98	3842	3579	3277	3517	3253	2952	3358	3094	2793	3033	2769	2467	3672	3409	3107	3347	3083	2782
99	4094	3815	3501	3758	3479	3165	3575	3296	2982	3239	2960	2646	3913	3634	3321	3577	3298	2985

* Weight of 2 rows and 6 rows are considered for heating and cooling coils, respectively

Table 5 - Weight of different parts of the 39HX series Air Handling Unit (kg)

Unit	Mixing Box	LVF	Pleated Filter	Bag Filter	Standard Coil (Rows)				Droplet Eliminator	Steam Humidifier	AC Fans	HEPA Filter
					1	2	4	6				
22	20	5	2	3	6	8	20	25	12	50	5	13
23	24	6	2	5	7	11	30	37	20	50	11	20
33	29	10	4	6	11	20	50	66	32	50	11	31
34	39	11	5	9	14	25	59	81	40	50	16	42
35	49	15	6	10	15	27	63	87	43	50	43	53
44	45	17	7	9	18	32	74	103	53	50	22	57
45	57	20	9	12	21	40	90	127	69	50	26	72
46	116	25	10	13	29	52	116	163	84	50	54	86
47	136	29	12	17	32	59	132	186	99	50	59	101
55	76	26	1	17	48	79	152	208	111	76	86	90
56	134	30	13	19	56	89	162	219	117	76	86	109
57	157	35	15	23	66	98	171	231	123	76	51	127
66	156	38	16	21	72	109	193	264	138	76	51	131
67	184	42	19	26	75	114	206	281	146	76	94	153
68	211	46	21	27	82	125	216	303	149	76	77	176
77	205	50	22	32	90	136	234	325	171	76	77	180
97	295	71	31	43	106	158	262	369	195	76	102	258
98	326	78	36	52	114	169	276	391	207	76	128	296
99	356	86	40	63	122	180	290	413	219	76	153	333

Grid Fan: 2

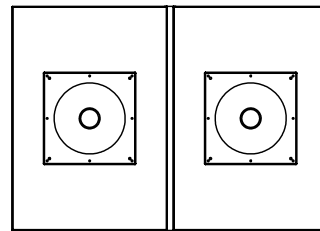

Grid Fan: 1



Grid Fan: 6

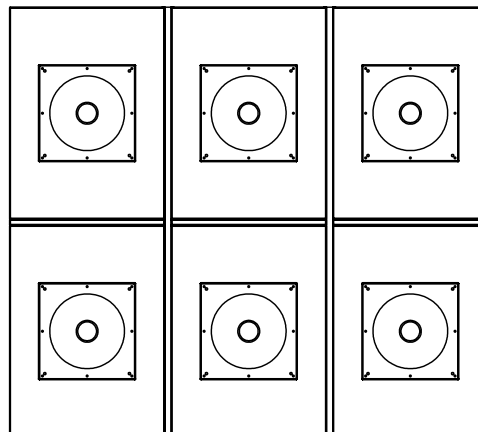

Grid Fan: 4

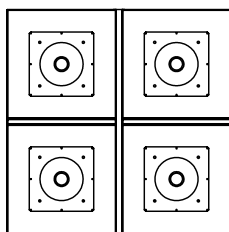

Pressure Loss of Filters

In the following diagrams, pressure losses for different kinds of filters used in 39HX series are shown. Diagrams show pressure loss for clean filters. In order to have a

realistic condition in selecting fans, both of the clean and dirty filter conditions should be taken into consideration. Following diagrams show pressure drop for different types of filters.

Design Pressure Drop Across the filters[inWg]						
FPM*	LVF-2"-G2	PLT-G4	Bag-M5	Bag-F8	Bag	HEPA-H14
200	0.03	0.11	0.12	0.24	0.39	0.96
250	0.04	0.13	0.16	0.30	0.49	1.14
300	0.05	0.16	0.21	0.36	0.58	1.32
350	0.06	0.19	0.26	0.42	0.67	1.49
400	0.07	0.22	0.31	0.48	0.77	1.65
450	0.09	0.26	0.37	0.54	0.86	1.81
500	0.10	0.30	0.43	0.60	0.95	1.97
550	0.12	0.35	0.49	0.67	1.05	2.12
600	0.14	0.40	0.55	0.73	1.14	2.27

*FPM = Air Flow Rate[CFM] / Face Area of each Filter[Sq. ft]

Face Velocity [FPM]	Heating Coil Air Pressure Drop [inWg]				Cooling Coil Air Pressure Drop [inWg]*					
	Row/FPI									
	1/8	1/12	2/8	2/12	4/8	4/12	6/8	6/12	8/8	8/12
200	0.02	0.05	0.02	0.05	0.09	0.11	0.13	0.16	0.15	0.21
250	0.04	0.07	0.04	0.07	0.13	0.17	0.19	0.24	0.23	0.32
300	0.06	0.09	0.06	0.09	0.18	0.23	0.26	0.33	0.32	0.44
350	0.08	0.12	0.08	0.12	0.23	0.29	0.34	0.43	0.40	0.56
400	0.10	0.15	0.10	0.15	0.28	0.36	0.42	0.54	0.50	0.70
450	0.13	0.18	0.13	0.18	0.34	0.43	0.51	0.65	0.59	0.84
500	0.16	0.22	0.16	0.22	0.40	0.51	0.60	0.77	0.69	0.99
550	0.19	0.26	0.19	0.26	0.46	0.60	0.70	0.90	0.80	1.15
600	0.22	0.30	0.22	0.30	0.53	0.68	0.80	1.03	0.91	1.32

* In case of high wet bulb temperature multiply with 1.5

AHU Size	Sections Face Area[sq. ft]				
	LVF	PLT	Bag	Coil	HEPA
22	6.8	3.7	4.0	2.1	3.7
23	10.1	5.7	6.0	3.9	5.7
33	15.1	8.5	9.0	5.8	8.5
34	20.3	11.5	12.0	8.3	11.5
35	25.2	14.1	15.0	10.8	14.1
44	27.0	15.1	16.0	11.1	15.1
45	33.5	18.8	20.0	14.4	18.8
46	40.6	22.7	24.0	18.1	22.7
47	47.1	26.4	28.0	21.4	26.4
55	42.0	23.5	25.0	18.1	23.5
56	50.7	28.2	30.0	22.6	28.2
57	58.8	33.2	35.0	26.7	33.2
66	60.8	33.8	36.0	29.3	33.8
67	70.6	39.6	42.0	34.8	39.6
68	81.0	45.1	48.0	40.6	45.1
77	82.4	46.4	49.0	40.1	46.4
97	118.2	66.6	70.1	59.4	66.6
98	135.1	75.2	80.1	67.3	75.2
99	152.0	84.6	90.1	75.2	84.6

Size Selection

Central station air handling unit selection usually starts with required airflow and preferred coil face velocity. Use the following formula to estimate the coil face area:

Coil Face Area (square feet) =

$$\frac{\text{Air volume flow rate (CFM)}}{\text{coil face velocity (fpm)}}$$

Use the following table to find the preferred unit size that has the suitable coil face area. To prevent moisture carry over for aluminum, copper and E-Coated fins use 550, 450, 400 as face velocity limit respectively otherwise use drift eliminator.

Example:

Given Data:

- Air Volume Rate: 14200 CFM
- Desired Coil Face Velocity: 475 fpm
- Sections: Aluminum filter, Bag (ePM10-90%), Cooling Coil, and Heating Coil
- External Pressure Drop: 0.9 inWg

$$\text{Coil Face Area} = \frac{14200}{475} = 29.9 \text{ (sq.ft.)}$$

According to table 1, AHU size 66 has 29.3 sq. ft. so coil face velocity is equal to 485 fpm. You can read following information from table 1:

Width: 1930 mm, Height = 2195 mm
Air Discharge Size = 905 mm

Form table 2, you can extract configuration Number and length.

Config. No. = 334, Length = 4663 mm

So the AHU model number is 39HX33466. This model does not include HEPA Filter therefore lookup weight in table 4. Note that in this table heating and cooling coil are considered 1 and 6 rows, respectively. Weight of 39HX33466 = 2069 kg. In case of coil's update, use table 5 for modification of unit weight.

2.1 Casing

The 39HX series have a frame, made from hollow aluminum profile with two chambers that are joined together. Aluminum profiles in 39HX series have the following specifications:

Thermal break profile which reduces the cold and heat transfer between inner and outer area.

Using a single profile for each chamber reduces the possibility of leakage and contaminant entrance.

Having curved inner surfaces eliminates the accumulation of dusts and contaminants within the air handling units and makes cleaning easier.

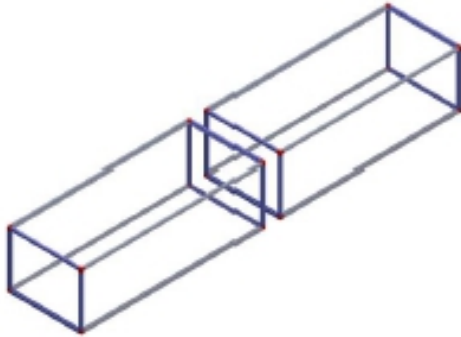

Two Chambers of Casing with Continuous Profiles

The profile holds a 42 mm dual-skin casing wall with panels, doors, inspection hatches and removable center posts. The standard casing wall construction of 39HX series consists of 1mm internal and 1.5 mm external plates made of galvanized steel. The XPS (Extruded Polystyrene) insulation inserted between the skins of the panels is non-flammable and also has acoustic and thermal insulating properties.

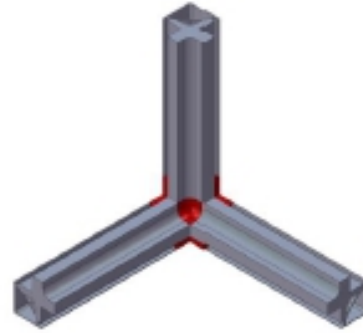

As various markets have different requirements, there are also versions with different plate materials, such as stainless steel.

The casing of 39HX series achieves a great mechanical performance when measured against Eurovent test standards of EN1886:2007. Mechanical characteristics of the 39HX series are listed in the following table:

Unit	Mechanical Strength	Body Sealing	Thermal Transmission	Thermal Bridging
39HX Series	D1	L1	T2	TB2

2.2 Filters

People spend on average up to 90% of their life indoors not only at home, but also in various places such as offices, schools, restaurants, shopping malls or cinemas. It goes without saying that having a clean indoor air is crucial for the health of the population as a whole and in particular vulnerable groups such as babies, children, patients and elderly people.

Numerous studies have proven a close correlation between Indoor Air Quality (IAQ) and our health. These also show that particular matter (PM) affects people more than any other pollutants. Air filters play an essential role in all kinds of indoor climate areas. Applying correctly selected, efficient air filters in ventilation systems can significantly reduce the amount of particle matters. It also has a strong impact on the energy performance of buildings as well as air handling units.

Standards for Coarse and Fine Dust

Filters

There are two European standards defining the filtration performance of filters for general ventilation. The well-known EN 779:2012 and the new global standard EN ISO 16890:2016. Both standards Deal with the evaluation of the filtration effect of coarse and fine dust filters used in general ventilation. Yet, in EN 779:2012 the efficiency classification for medium and fine filters is based on $0.4\mu\text{m}$ particles, while EN ISO 16890 defines the efficiency for various fractions of particle size, namely: PM₁₀, PM_{2.5}, PM₁, and coarse dust, where PM stands for Particulate Matter.

The ISO 16890 test standard has been valid for the classification of air filters since January 2017 and, since August, also as DIN EN ISO 16890:2017. Since July 2018, it has completely replaced the previous industry standard EN 779. The advantage of ISO 16890 is that filter efficiency is determined realistically, which reflects the overall dust classification system recommended by the World Health Organization (WHO). This makes the selection of the best possible filters for different requirements much easier.



EN 779:2012 Standard

In many countries in the world, the coarse and fine dust filters used in air-conditioning and ventilation systems are usually selected in accordance with the classification described in the EN 779 standard entitled "particulate air filters for general ventilation". The methodology described in this standard is based on a laboratory test procedure, with the aim of achieving reproducible and comparable results. However, since the test aerosols and test dusts used will not usually resemble the air pollutants that an air filter is exposed to in actual

operation, the results of the laboratory test are transferable to actual applications only with very restricted relevance.

For coarse filters, the filter effect is evaluated by measuring initial gravimetric arrestance when challenging the filter with synthetic test dust using ASHRAE test dust. For fine filters, the filter effect is evaluated by measuring the efficiency against 0.4µm DEHS droplets. The classification of classes defined in EN779:2012 is shown in the following table:

Coarse	Class	Final pressure drop (pa)	Average arrestance (Am*) of synthetic dust	Average efficiency (Em**) of 0.4 µm particles (%)	Minimum efficiency (Em) of 0.4 µm particles (%)
Filter Group	G1	250	50≤Am<65	-	-
	G2	250	65≤Am<80	-	-
	G3	250	80≤Am<90	-	-
	G4	250	90≥Am	-	-
Medium	M5	450	-	40≤Em<60	-
	M6	450	-	60≤Em<80	-
Fine	F7	450	-	80≤Em<90	35
	F8	450	-	90≤Em<95	55
	F9	450	-	95≥Em	70

This standard evaluates the filtration efficiency for the particle size of 0.4µm. However, the particle spectrum in the outdoor air is much wider. This means that a large

proportion of the hazardous particulate matter is not taken into account during the measurement process of this standard.

ISO 16890 Standard

In contrast to EN 779, the test procedure according to ISO 16890 is much more differentiated and is based on the local air quality of the respective process site. Unlike the old standard, the filters are rated in the test according to a broad particle range of 0.3-10 microns. This is derived from the typical dispersion densities of urban and rural regions. The advantage is that the filter takes into account the actual particle sizes prevailing the air. The filters are classified according to the Particulate Matter classes

PM1, PM2.5, PM10, and coarse dust (ISO coarse). The ISO 16890 standard thus uses the same evaluation parameters as the World Health Organization (WHO) uses for measurement. For coarse filters, the filter effect is evaluated by measuring the initial gravimetric arrestance when challenging the filter with synthetic test dust using AC-fine test dust. For fine filters, the fractional efficiency is measured in the range of 0.3 to 10µm particle diameter. The following picture shows a comparison between different particulate matter sizes.



To be assigned to a specific particulate matter group in this standard, filter needs to retain at least 50 percent of the corresponding particle size range. Filter that capture less than 50 percent of PM10 particles are designated as coarse dust filters. The efficiency of the filter is given in

down-rounded 5-percent increments. A filter that captures 87 percent of PM1 particles is thus classified as ISO ePM1 85%, where the “e” stands for “efficiency”. The following table shows particulate matter size classification.

Particulate matter size classification according to ISO 16890		
Classes	Particulate Matter Diameter	Minimum Efficiency
ISO ePM1	0.3<x<1	e(PM1), min≥50%
ISO ePM2.5	0.3<x<2.5	e(PM2.5), min≥50%
ISO ePM10	0.3<x<10	e(PM10), min≥50%
ISO coarse	0.3<x<10	e(PM10), min≤50%

The direct conversion of EN 779 and ISO 16890 classes is not possible. To facilitate an indicative comparison, particularly for the purpose of replacing existing filters,

the Eurovent Association has developed the following table matching both EN 779 and ISO 16890 classes for the same filters.

EN 779:2012	ISO 16890 Range of actual measured average efficiencies		
Filter Class	ePM ₁	ePM _{2.5}	ePM ₁₀
M5	5% - 35%	10% - 45%	40% - 70%
M6	10% - 40%	20% - 50%	60% - 80%
F7	40% - 65%	65% - 75%	80% - 90%
F8	65% - 90%	75% - 95%	90% - 100%
F9	80% - 90%	85% - 95%	90% - 100%

Standard for High Efficiency Air Filters (EPA, HEPA, ULPA)¹

When the very highest levels of air purity are required - for example clean rooms for the pharma or food industries, or in hospital operating theatres - EPA, HEPA, and ULPA filters are the solution. These filters are classified based on the values for local particle collection efficiencies (local values) and integral efficiency (integral

value). Each is assessed on the basis of the most penetrating particle size (MPPS). For the classification of EPA filter, a leak testing is not possible and not necessary. Therefore, no local values as leak detection limits are given for this group.

To test the filter element, it is subjected to a constant airflow from an aerosol with an

¹ EPA: Efficient Particulate Air filter
HEPA: High Efficiency Particulate Air filter ULPA: Ultra Low Penetration Air filter

average particle size which corresponds to the hardest particle size to capture (MPPS: Most Penetrating Particle Size). Using movable probes, local particle concentrations are measured on the downstream side, which give together with the particle concentrations

measured on the upstream side the result for the local penetration and the local collection efficiencies, respectively. The integral efficiency is calculated by averaging the local results.

Filter Group	Class	MPPS* integral Values		MPPS Local Values	
		Efficiency(%)	Penetration(%)	Efficiency(%)	Penetration(%)
EPA	E10	85	15	-	-
	E11	95	5	-	-
	E12	99.5	0.5	-	-
HEPA	H13	99.95	0.05	99.75	0.25
	H14	99.995	0.005	99.975	0.025
ULPA	U15	99.9995	0.0005	99.9975	0.0025
	U16	99.99995	0.00005	99.99975	0.00025
	U17	99.999995	0.0000	99.9999	0.0001

***MPPS: Most Penetrating Particle Size**

An important issue for filters used in air handling units beside their permeability is their installation to the inner surface of the air handling unit. If proper sealing is not provided between the filter frame and inner surface of the air handling unit, air shall penetrate through the holes it can find and prevent the filter from operating

efficiently. On this issue, there is a filter bypass leakage classification as per EN1886 that measures the efficiency of the installation and is shown in table blow. This table lists the total admissible bypass leakage k in % of the design air flow over the filters as a function of the built-in filter class. The standard slide-in construction for filters in 39HX series is suitable for filter class F9.

Maximum filter bypass leakage allowed as per EN1886-2007					
Filter Class	G1-F5	F6	F7	F8	F9
Total bypass leakage k%	6	4	2	1	0.5

A wide variety of filter types is available to meet any filtration requirements, including low velocity filter, pleated filter, bag filter, HEPA filter and other types.

Filters are divided into categories as per their particle permeability, material structures, intended uses and their placing inside the air handling unit.

Low Velocity Filter (LVF)

Low Velocity Filters (Metal Filters) are washable and consist of multi-layered aluminum flat wire. These filters are arranged in v-bank housing which increases the filtration area. Filter class: G2-G3 Filter thickness: 50 mm Filter frame: Galvanized steel



Bag Filter

Bag filters are arranged vertically and increase the area of filtration. These filters are made of synthetic fibers. Filter category: M5-M6-F7-F8-F9 Bag length: 500 mm Filter frame: Galvanized steel



Pleated Filter

Pleated filters are made from finely woven synthetic mats. They are mostly used in initial stages of filtration. Filter class: M5, M6 Filter thickness: 50 mm Filter frame: Galvanized steel



HEPA Filter

HEPA filters consist of a high-quality fiberglass medium. These filters are used for rooms with extended hygiene requirements. Filter class: H13-H14 Filter thickness: 300 mm Filter frame: Galvanized steel



2.3 Coils

Heat exchangers used for heating, cooling and/or dehumidifying the air in HVAC systems are usually of the finned pipe type and they are called as coils. Air to be conditioned that flows outside of the finned pipes contact the fin surface. A heating or cooling fluid is circulated inside the pipes. Coils may be hot water coils, vapor coils, cold water coils, DX coils and electric coils. We manufacture all types of coils in our own coil workshop. 1/2" pipe is used in 39HX air handling unit coils.

All water type coils manufactured are tested with the 30 bar pressurized air test in the water pool inside the factory. Test pressure of DX coils vary as per refrigerant type.

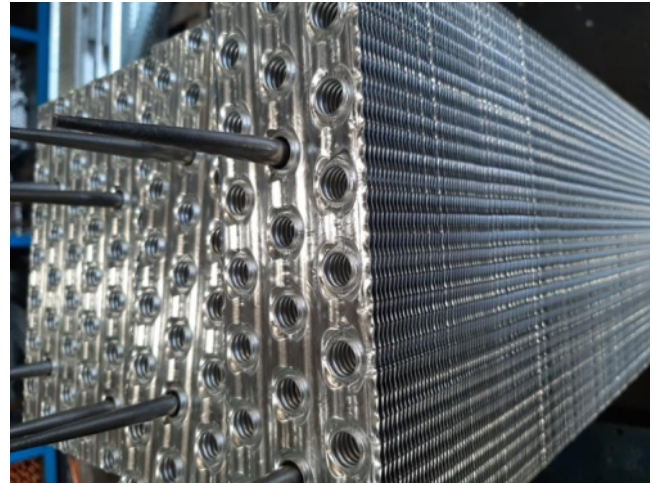

Physical Data (Chilled Water and Hot Water Coils)											
Unit Size	22	23	33	34	35	44	45	46	47	55	56
cfm at 550 FPM	1155	2145	3190	4565	5940	6105	7920	9955	11770	9955	12430
Face area (sq.ft)	2.1	3.9	5.8	8.3	10.8	11.1	14.4	18.1	21.4	18.1	22.6
Tube Face	16	16	24	24	24	32	32	32	32	20/20	20/20
Connection Size(in) Cooling Coil	3-in MPT supply and return										
Connection Size(in) Heating Coil	2-in MPT supply and return										

Physical Data (Chilled Water and Hot Water Coils)									
Unit Size	57	66	67	68	77	78	71	81	91
cfm at 550 FPM	14685	16115	19140	22330	22055	25795	32670	37015	41360
Face area (sq.ft)	26.7	29.3	34.8	40.6	40.1	46.9	59.4	67.3	75.2
Tube Face	20/20	16/36	16/36	16/36	28/32	28/32	28/32	32/36	24/24/28
Connection Size(in) Cooling Coil	3-in MPT supply and return								
Connection Size(in) Heating Coil	2-in MPT supply and return								

UNIT SIZE	Circuiting Type	Total Number of TXV's	Coil Section Face Area (sq ft)	Suction Connections Diam (in. OD)	Liquid Refrigerant Diam (in. OD)*
22	Quarter	2	2.1	1	1/2
	Half	2	2.1	1 1/8	1/2
	Full	2	2.1	1 3/8	5/8
23	Quarter	2	3.9	1	1/2
	Half	2	3.9	1 1/8	1/2
	Full	2	3.9	1 3/8	5/8
33	Quarter	2	5.8	1	1/2
	Half	2	5.8	1 3/8	5/8
	Full	2	5.8	1 5/8	5/8
34	Half	2	8.3	1 3/8	5/8
	Full	2	8.3	1 5/8	5/8
35	Half	2	10.8	1 3/8	5/8
	Full	2	10.8	1 5/8	5/8
44	Half	2	11.1	1 3/8	5/8
	Full	2	11.1	1 5/8	5/8
45	Half	2	14.4	1 3/8	5/8
	Full	2	14.4	1 5/8	5/8
46	Half	2	18.1	1 3/8	5/8
	Full	2	18.1	1 5/8	5/8
47	Half	2	21.4	1 3/8	5/8
	Full	2	21.4	1 5/8	5/8

UNIT SIZE	Circuiting Type	Total Number of TXV's	Coil Section (Upper / Lower)	Face Area (sq ft)	Suction Connections Diam (in. OD)	Liquid Refrigerant Diam (in. OD)*
55	Half	4	U	9.05	1 1/8	5/8
			L	9.05	1 1/8	5/8
	Full	4	U	9.05	1 3/8	5/8
			L	9.05	1 3/8	5/8
56	Half	4	U	11.3	1 1/8	5/8
			L	11.3	1 1/8	5/8
	Full	4	U	11.3	1 3/8	5/8
			L	11.3	1 3/8	5/8
57	Half	4	U	13.35	1 1/8	5/8
			L	13.35	1 1/8	5/8
	Full	4	U	13.35	1 3/8	5/8
			L	13.5	1 3/8	5/8

UNIT SIZE	Circuiting Type	Total Number of TXV's	Coil Section (Upper / Lower)	Face Area (sq ft)	Suction Connections Diam (in. OD)	Liquid Refrigerant Diam (in. OD)*
66	Half	4	U	9	1 1/8	5/8
			L	20.3	1 3/8	5/8
	Full	4	U	9	1 3/8	7/8
			L	20.3	1 5/8	7/8
67	Half	4	U	10.8	1 1/8	5/8
			L	24	1 3/8	5/8
	Full	4	U	10.8	1 3/8	7/8
			L	24	1 5/8	7/8
68	Half	4	U	12.5	1 1/8	5/8
			L	28.1	1 3/8	5/8
	Full	4	U	12.5	1 3/8	7/8
			L	28.1	1 5/8	7/8
77	Half	4	U	18.7	1 3/8	5/8
			L	21.4	1 3/8	5/8
	Full	4	U	18.7	1 5/8	7/8
			L	21.4	1 5/8	7/8
97	Half	4	U	27.7	1 3/8	5/8
			L	31.7	1 3/8	5/8
	Full	4	U	27.7	1 5/8	7/8
			L	31.7	1 5/8	7/8
	Double	8	U	27.7	1 5/8	1 1/8
			L	31.7	1 5/8	1 1/8
98	Half	4	U	31.7	1 3/8	5/8
			L	35.6	1 3/8	5/8
	Full	4	U	31.7	1 5/8	7/8
			L	35.6	1 5/8	7/8
	Double	8	U	31.7	1 5/8	1 1/8
			L	35.6	1 5/8	1 1/8
99	Half	6	U	23.75	1 3/8	5/8
			U	23.75	1 3/8	5/8
			L	27.7	1 3/8	5/8
	Full	6	U	23.75	1 5/8	7/8
			U	23.75	1 5/8	7/8
			L	27.7	1 5/8	7/8
	Double	12	U	23.75	1 5/8	1 1/8
			U	23.75	1 5/8	1 1/8
			L	27.7	1 5/8	1 1/8

2.4 Humidifier

Humidifier is one of the most important and critical components of the air handling unit. By heating outside air during the cold season, humidity indoors can be lowered to below 30% RH. Persons who are exposed to such dry room air over a longer period then often suffer from drying phenomena. So, adequate humidification during the heating period therefore leads to comfortable room air quality and is conducive to health. The following picture shows comfort diagram based on relative humidity and temperature.

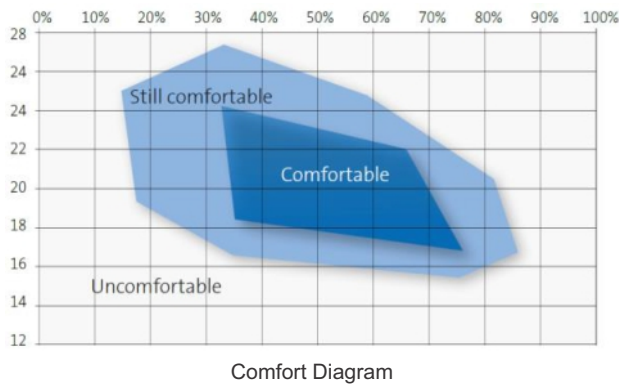

Generally, there are two types of humidifiers for air handling units, and they are distinguished according to their function. Adiabatic humidifiers, such as evaporative humidifiers and high pressure spray humidifiers are characterized by an almost isenthalpic state change. These humidifiers include evaporative and high pressure spray humidifiers. Other humidifiers used in air handling units, such as steam humidifiers, are isothermal humidifiers.

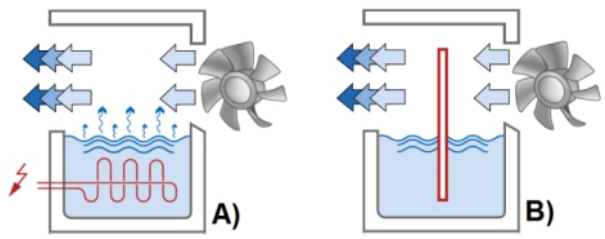

Schematic Principle of A) Steam and B) Adiabatic Humidifier

It is very important that length of humidifier section is sized properly to prevent drift of water drops to the components after the humidifier. Also, the drain pan and the draining of the water shall be considered with care as it is cell that contains water and steam. Materials used in the drain pan of 39HX series are selected carefully in order to prevent corrosion and any possible contaminant accumulation.

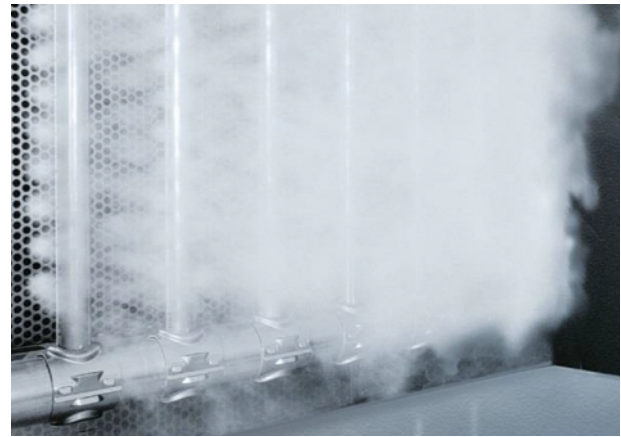

For reason of hygiene, only steam humidifiers are to be used in operating departments (DIN1946-4).

2.5 Fans

Most of the energy consumed by an air handling unit is the electricity used to run the fan motor, whilst only a small percentage of the energy goes to heat generation. Therefore, high fan efficiency means power saving. Free running impellers with EC or AC external rotor motors are particularly characterized by their high power-to-weight ratio in conjunction with the compact drive concept. With no belts or sheaves, and fewer bearings, these fans are more reliable and require less maintenance than belt-drive fans. Direct drive enables this fan type to be used in a wide variety of applications in accordance with hygiene requirements (DIN 1946, VDI 6022). Plug fans provide the following advantages:

- Very compact length
- It is possible to combine several fans in parallel making a fan array
- Direct drive, no power losses due to a belt drive
- No belt abrasion, suitable for hygiene applications
- Low maintenance and easy cleaning

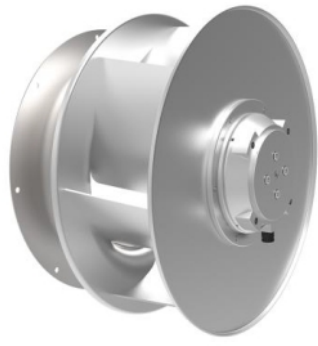

Direct drive AC plug fan

Sarma-Afarin hygienic air handling units include multiple AC or EC plug fan assemblies arranged in a fan array. Fan arrays provide the following advantages:

- Increased redundancy in the event of fan failure
 - More homogenous flow pattern through the coils and better flow distribution
 - Better sound spectrum that is easier to attenuate with conventional insulated ductwork
 - Less AHU unit length and footprint than units incorporating large single fan/motor designs
 - Standardization of components reduces inventory requirements, facilitates prompt identification and replacement, and provides for ease of service
- Reduced maintenance scope and cost as components are smaller and easier to handle and transport in the event replacement is required. All fans incorporate sealed for life bearings and eliminate maintenance and alignment issues associated with belt and pulley drive systems
 - Great for retrofit applications
 - Where (optional) backdraft dampers are installed, the ideal quantity of fans only need to be enabled during after-hours use, to ensure efficient operation without risk of instability

3.1 Applications with Extended Hygiene Requirements

When air handling units are used in hospitals, pharmaceutical plants or special industrial facilities, they shall provide some hygiene standards according to the site that they shall be conditioning the air inside. These standards may vary from one room of the site to another. For example, in a hospital even the operating rooms may have different requirements as per the type of operation to be performed. While many air handling unit manufacturers offer hygienic air handling units as a different series, Sarma Afares 39HX air handling units can be manufactured to meet the hygiene standards by the

specifications that can be selected from the selection software as they are full flexible units. In the 39HX series with extended Hygiene requirements, a stage of filtration with HEPA filters is included at the end of the air handling unit. Moreover, Hygiene requirements are observed at the highest level according to the available standards. Although hygiene criteria varies as per the criteria of the relevant sites, we have observed the hygiene criteria as below, which are in conformity with EN1886, EN13053, EUROVENT (RS 6/C/011-2017), DIN1946-4, and VDI6022 standards. In the following Tables, hygiene criteria that are observed in the 39HX series with extended hygiene requirements are listed:



Casing and Panels	Standard(s)
Panel/profile connections without drilling the panel body	EUROVENT
Thermal Bridging TB2	EN1886, EUROVENT
Casing strength D1	EN1886
Thermal transmittance T2	EN1886
Casing air leakage L1	EN1886, EUROVENT
Filter bypass leakage F9	EN1886
Lower parts of the casing which could potentially be in contact with condensation water are made of stainless steel	DIN1946-4, EUROVENT
Completely smooth interior surfaces without sharp edges	DIN1946-4, EUROVENT

Coils and Humidifier	Standard(s)
Minimum thickness of 0.004 mm for fins	EUROVENT
The distance between the fins is 2mm	EUROVENT, EN13053
All drain pans and condense trays have a sufficient slope and are made of stainless steel	EUROVENT, VDI6022, DIN1946-4
For reason of hygiene, only steam humidifiers are used	DIN1946-4
For hygiene reasons, coolers with dehumidification and humidifiers are not arranged immediately before air filters	EUROVENT, DIN1946-4, VDI6022

Filters and Fans	Standard(s)
Filters are installed near the outdoor air suction opening and at the end of the air handling unit	DIN1946-4, EUROVENT
Air filters are changeable from dusty air side	DIN1946-4, EUROVENT, VDI6022
The use of air filters of higher classes is recommended for hygiene reasons	VDI6022
Each filter stage is equipped with a differential-pressure gauge	VDI6022, EUROVENT
No recirculated air is allowed	EUROVENT
For hygiene reasons, fans without spiral casing and belt-drive are used (EC plug fans)	EUROVENT, DIN1946-4, VDI6022

The remote monitoring system is provided by Sarmaafarin on its chillers and packages on request of customers. By directly connecting the monitoring system to the main control unit, all information and alarms can be transmitted to any location via a fixed connection line. Real time monitoring of operating conditions on installed units, recording of data in abnormal situations, maintenance management and

setting desired temperature in the home from a smart phone, are just some of many opportunities provided to designers and users of home systems at any time and from anywhere. Storing customer information for at least one year has a significant impact on the proper functioning and operational life of the system, making it easier to maintain the system.

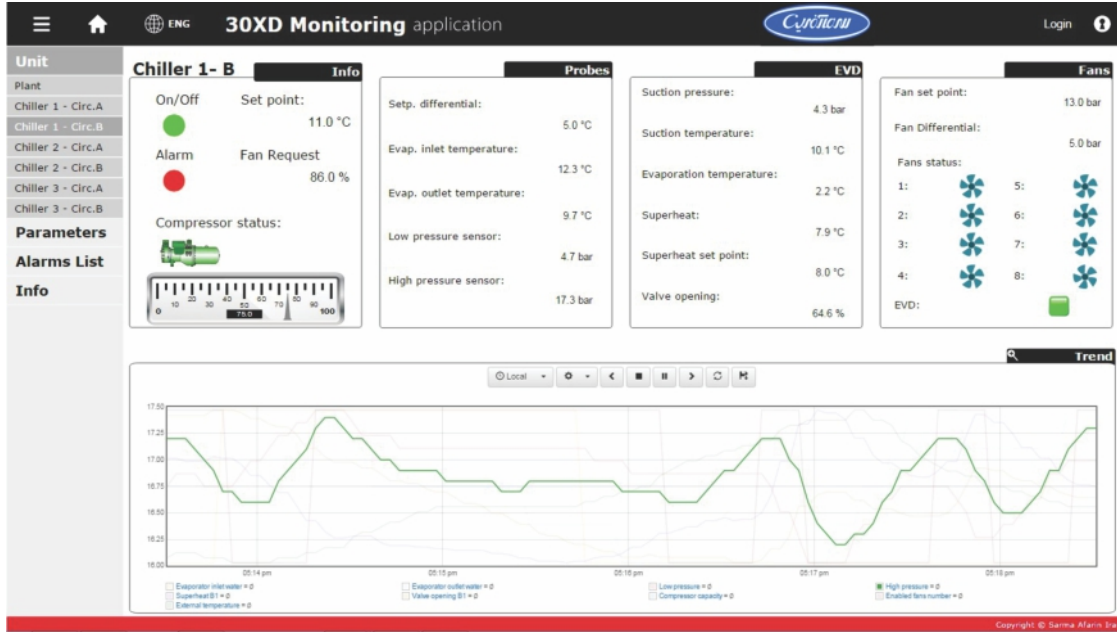

Features and Benefits of Monitoring

- Observation of important parameters at any moment
- Displaying the current status of system on a chart based on live data
- Recording important values in the case of abnormal events
- Quick diagnosis of system faults and troubleshooting from anywhere
- Customized pages for the customer
- Selecting important parameters, notifications and warnings by the custom
- Applicable settings via PC or Smart phone
- Different access levels with specific passwords for users
- Collecting and building an annual archive of information



Selection Software

Sarma Afarin 39HX Air Handling Unit consists of multiple sections that make it flexible to meet the expectations of a wide range of customers. Sarma Afarin A.H.U. selection

software has made it easy for users to select their required sections and see the performance of their air handling unit in advance. The following pictures show some pages of our selection software output.

General Data	
Project Name	SarmaAfarin
Customer Name	R&D
Letter Date	1398/09/27
Offer Number	95151201
Revision	1.0.0
AHU Type	39HX
With Reference to	
To Fulfill	



Customer Information	
Project City	Tehran
Project Address	----
Customer ID	
Contact Tel.	----
Contact Email	----

AHU No./Tag	1	1
Unit Size	39HX12177	

Customer Request		
Air Flow	24000 cfm	
External Pressure Drop	inH2O	
Altitude	5900 ft	
Requirement Cooling	528000 Btuh	
Requirement Heating	432000 Btuh	
AHU No./Tag	1	1
Unit Size	39HX12177	

Coils Inlet Condition		
Cooling	Air Temperature Dry / Wet	80/67 oF
	Water Temperature	44°F
	Water Flow Rate	105.6 gpm
Heating	Air Dry Temperature	68 °F
	Water Temperature	180 °F
	Water Flow Rate	43.2 gpm
	Inlet/Outlet Side	Right

Cooling Coil (Chilled Water) - Outlet Condition		
Specifications (Row/FPI/Fin/Circuit)	4/8/Aluminium/Full	
Total Cooling Capacity / Deviation	605091.9 Btuh 15%	
Sensible Cooling Capacity	526081 Btuh	
Leaving Air Temperature Dry / Wet	61.6/60.9°F	
Leaving Water Temperature	53.9 °F	
Face Area/Face Velocity	40.1 sq. ft	599 FPM
Pressure Drop Water/Air Side	37.8/0.606 inH2O	

Heating Coil (Hot Water) - Outlet Condition		
Specifications (Row/FPI/Fin/Circuit)	2/8/Aluminium/Full	
Heating Capacity / Deviation	925463.6 Btuh 1.1e+02%	
Leaving Air Temperature	107 oF	
Leaving Water Temperature	137 oF	
Pressure Drop Water/Air Side	11.8/0.258 inH2O	

DX Coil		
Specifications (Row/FPI)	4/12	

4.3 Tests

We conduct different types of tests on 39HX air handling units to ensure the trouble-free operation of the units. Besides the tests required for installation and manufacturing per component (coil leak, fan balancing, noise measurement, etc.) for air handling unit, each unit is also tested for final quality control as a finished product in Sarma Afarin factory.

Sarma Afarin company has a test planning process for each kind of product, which measures all the necessary parameters.

Other than the standard quality control tests, both product development and performance tests may be performed in great details. Pressure Test



Pressure Test of Heat Exchangers

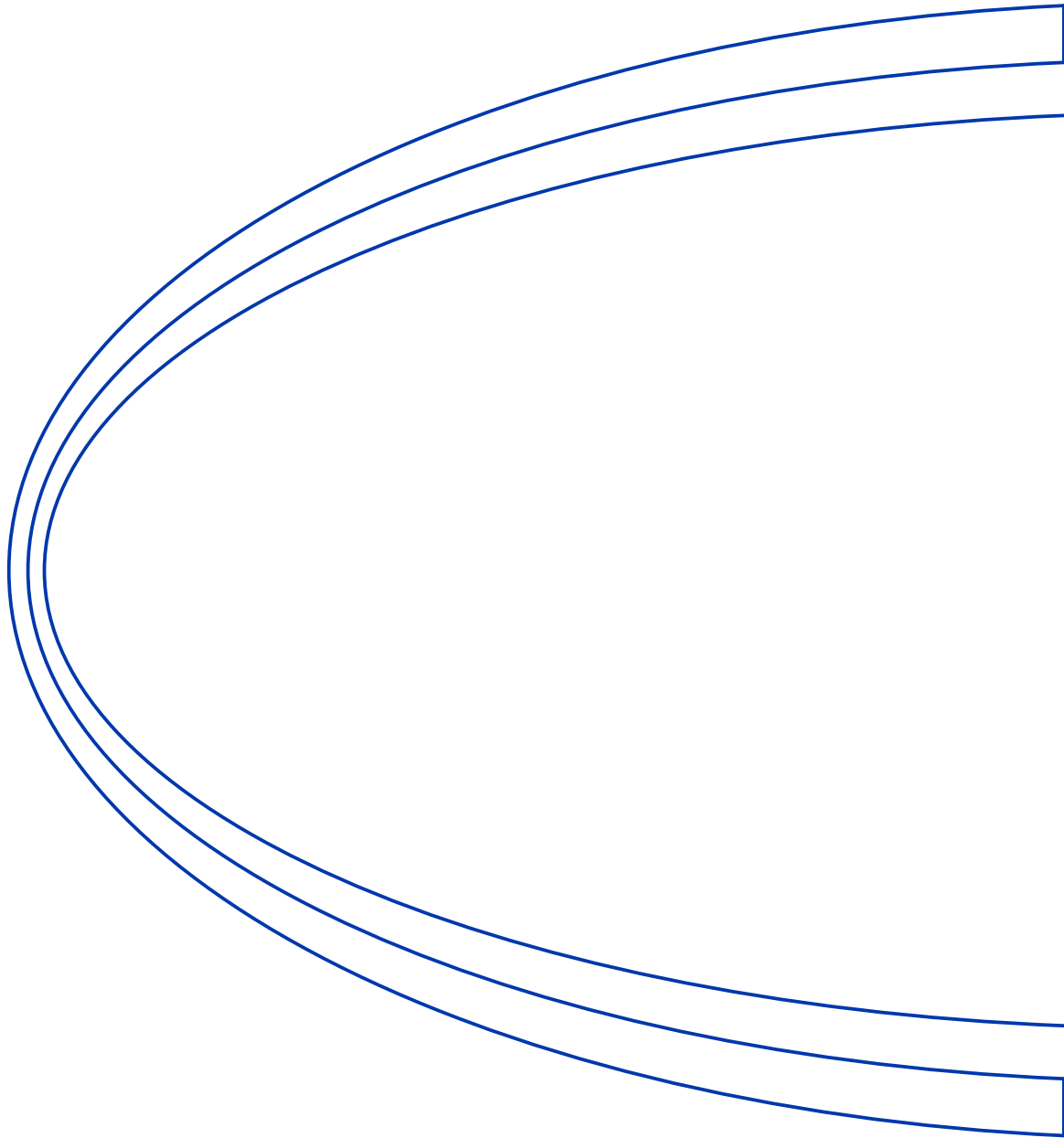

Sanaye Sarmaafarin Iran

شرکت صنایع سرما آفرین ایران
(کریر ترموفریگ)

No. 194, W. Khorramshahr (Apadana) Ave., TEHRAN-15337, P. O. BOX: 13145-1799 Tel: 88762038 Fax: 88762033 www.sarmaafarin.com

سهرودی شمالی، خیابان خرمشهر، شماره ۱۹۴، تهران - ۱۵۳۷۷، صندوق پستی: ۱۷۹۹-۱۳۱۴۵ تلفن: ۸۸۷۶۲۰۳۸ فاکس: ۸۸۷۶۲۰۳۳

Manufacturer reserves the right to discontinue or change at time, specifications of designs without notice and without incurring obligations